



1 2 0 7 °



1 2 0 7 °



SiO₂

INNOVATION 01.

= PHILOSOPHY =

Extraordinary products for
ordinary needs.

A50 - 7Cu5
1030° / 1207°
Mex. - Mor.



AUDACITY

02.

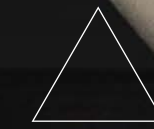

= CONFIGURATION =

Singular designs with contemporary features.

A50 - 7Cu5
1030° / 1207°
Mex. - Mor.



SIMPLICITY
N' ELEGANCE
03.

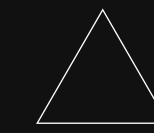

= V A L U E S =

The design is in the details.



A50 - 7Cu5
1030° / 1207°
Mex. - Mor.

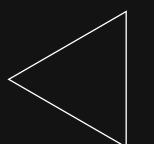

STUDIO . YOHO

We are an independent design studio created in 2010 and headquartered in Mexico City. We have a ceramics workshop in Xochicalco, Morelos.

M E X I C A N
D E S I G N
A N D
I N N O V A T I O N

YOHO is a word of Otomi origin meaning "two", as the number of members who started and gave life to the project: Manuel Estrada (CEO of the study) and Karen Guerrero.

Since our inception, the goal of Yoho was to design and create **extraordinary products for ordinary needs**. Our philosophy, our products are always innovative.

In Yoho we have values like audacity, simplicity and elegance. And a particular vision and collectivity, to meet the needs of each project. If you are interested that we develop your project, buy our products or any creative collaboration;
c o n t a c t . u s .

ONLY.WITH.INNOVATION.THE.DESIGN.TRANSCEnds



Y O H O IS THE POINT WHERE THE CONTRASTS ARE FOUND: live and neutral colors, clays and glazes, smooth and textures, organic and artificial, formal and playful. In addition, converge latin and global features, always with a **CONTEMPORARY AESTHETIC AND CONSTANTLY CHANGING.**

SERVICES

Our services are characterized by their versatility, in the design area. As we contribute in building a creative and innovative culture

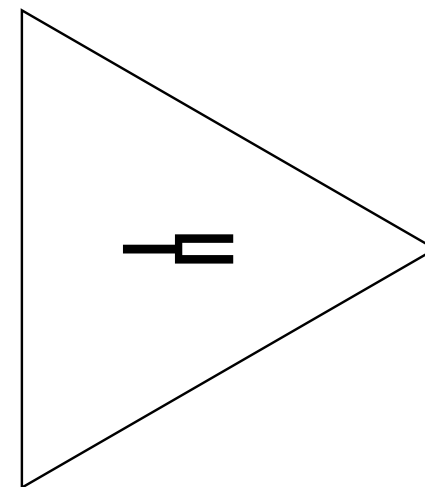

E S T U D I O - Y O H O - 2 0 1 6

CERAMIC DESIGN

BEING LED BY INDUSTRIAL DESIGNERS, YOHO APPROACH IS
TO CREATE OBJECTS-PRODUCT WITH A CONCEPT OF USEFUL
AND NOVEL DESIGN.





P R O J E C T
D E V E L O P M E N T

WE OFFER COMPREHENSIVE DESIGN, BOTH CERAMIC AND ANY
OTHER OBJECT; FROM THE CONCEPTUAL STAGE TO THE
PROJECTIVE (ENGINEERING DESIGN), EXECUTIVE AND
PRODUCTIVE IN SOME CASES.

A photograph of a ceramics workshop. In the foreground, a row of dark, rectangular ceramic tiles is laid out on a wooden workbench. Behind them, several larger, light-colored ceramic pieces, possibly vases or bowls, are visible. The background is slightly blurred, showing more of the workshop environment. The text is overlaid on the image in a clean, white, sans-serif font.

CERAMICS WORKSHOP

MANUFACTURE OF CERAMICS FROM DESIGNS PROPOSED BY
THE CUSTOMER.

WITH A WIDE RANGE OF FINISHES IN LOW AND HIGH
TEMPERATURE.

—
P R O D U C T S

A50 - 7Cu5
1030° / 1207°
Mex. - Mor.

C R T . 8 0

N T . 0 0

B R . 1 0 0

C F . 7 0

R S . 5 0

S L . 1 0 0

P I G G Y
F I N I S H E S



—
P I G G Y

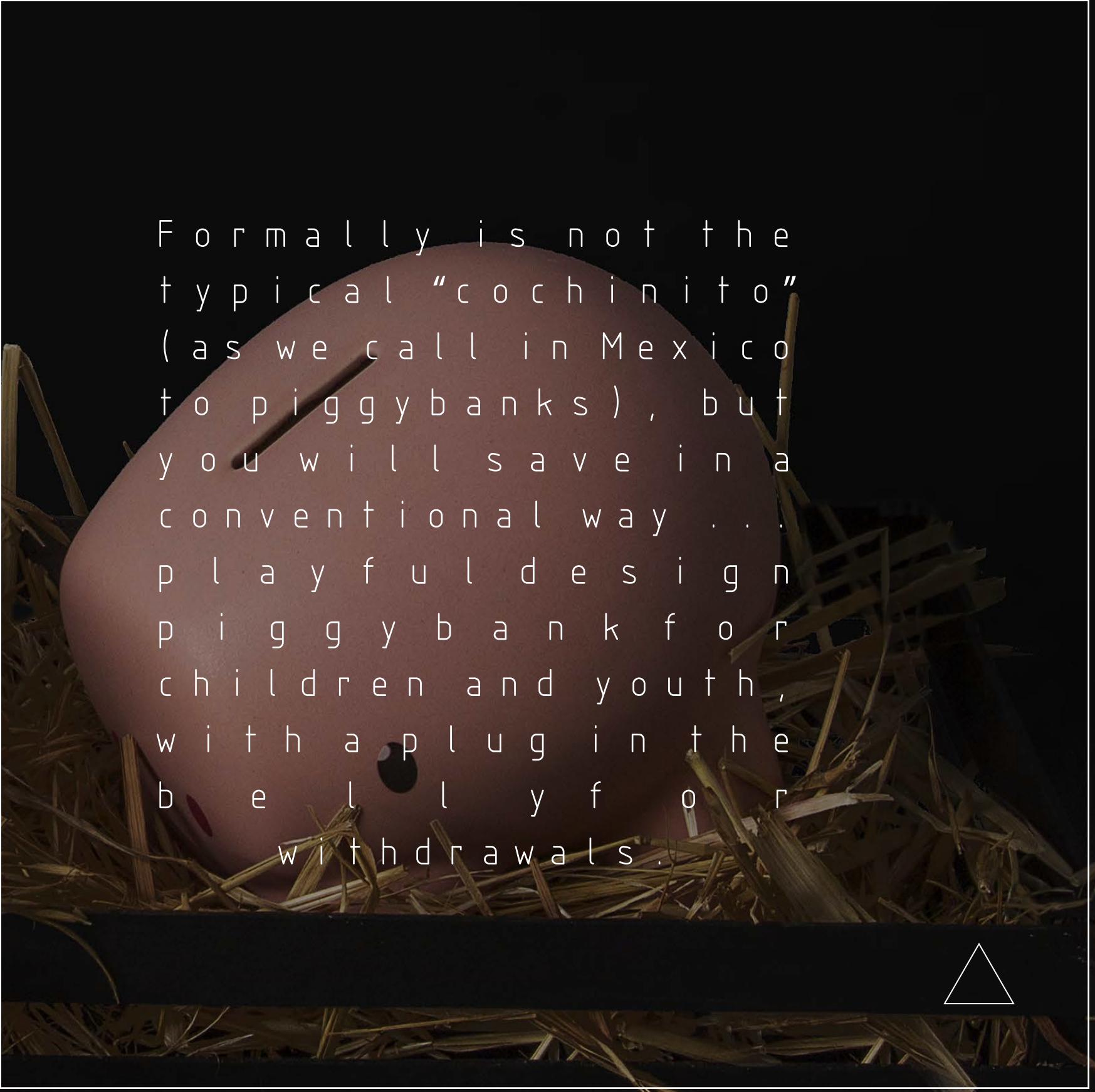

Formally is not the
typical "cochinito"
(as we call in Mexico
to piggybanks), but
you will save in a
conventional way...
playful design
piggy bank for
children and youth,
with a plug in the
belly for
withdrawals.



PIGGY

High temperature
ceramic piggybank
(Stoneware / cone 5)
enamel or engobe

finishes. The enamel have their
eyes, tail and nose ceramic
decal (burned). The engobe
finishes come with colored
chalk and sponge, to decorate
it. It has a cork in the belly
to withdraw your money.

Dimensions: 15x14x16 cm.

1 2 0 7

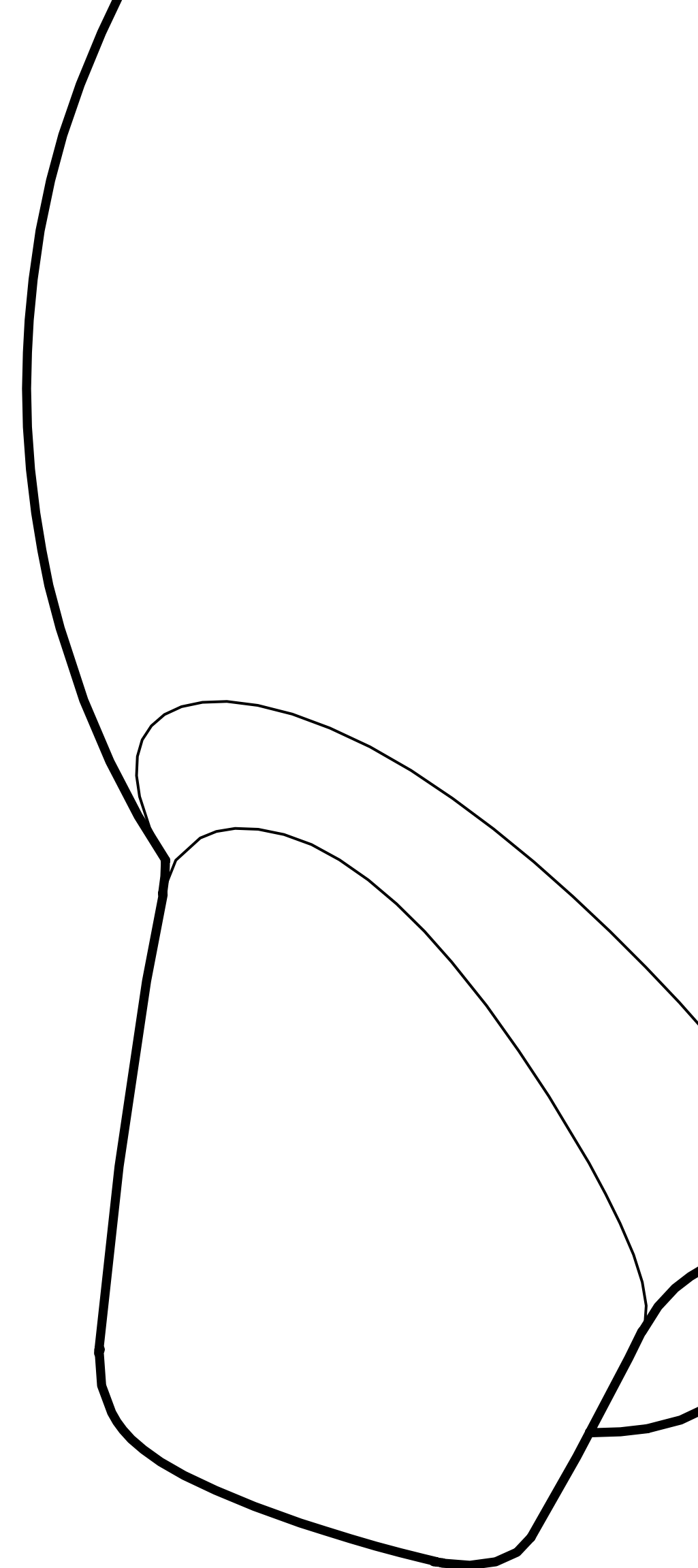

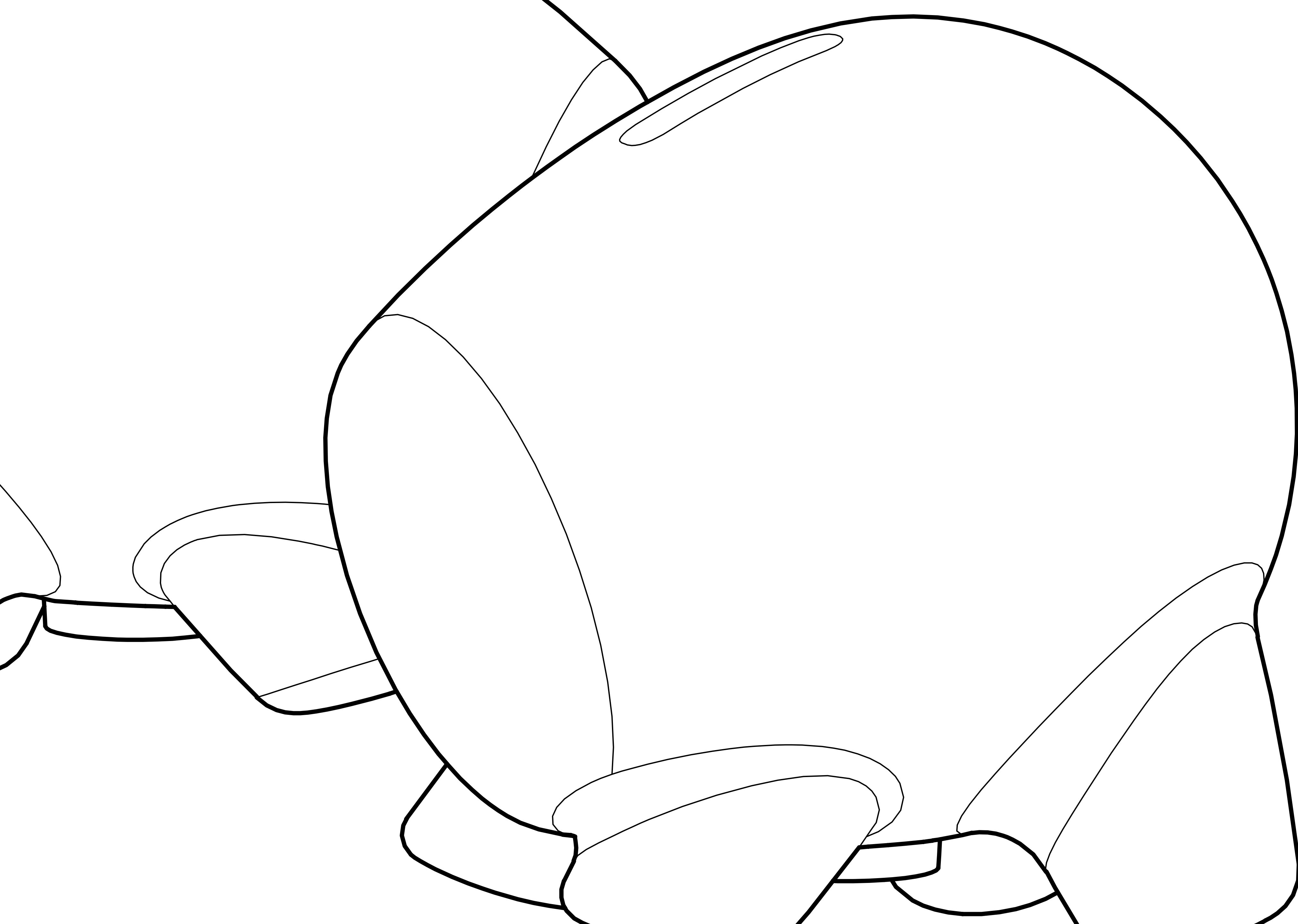

1 2 0 7

MATTE
SALMON

P I N K

M U D
1 0 0

B L A C K



W H I T E



CONCRETE



B L A C K
SANDPAPER



NATURAL



COFFEE



N G L . 8 0

C F . 7 0

B R . 1 0 0

N T . 0 0

B L . 1 0 0

N G . 1 0 0

D O N B U R I
F I N I S H E S



—
DONBURI/AKU

J a p a n e s e B o w l f o r
t r a d i t i o n a l d i s h e s
m a d e f r o m r i c e
(G o h a n) a n d a n y
k i n d o f o r i e n t a l
f o o d . I t h a s a p a i r
o f h o l e s t o p l a c e
y o u r c h o p s t i c k s ,
a n d d o n o t s t a i n
y o u r t a b l e .



DONBURI DONBURI.AKU

High temperature
ceramic bowl
(Stoneware / cone 5)
enamel, engobe
finishes or models

with ceramic decal (burned).
It can be used in the
microwave.

Capacity: 200 g.

Dimensions: 15 x 13 x 19 cm.

Pair of walnut or ash handmade
sticks 24cm long. Its
manufacturing process is
machined in CNC, hand-painted,
laser engraving and sealed with
linseed oil (non-toxic).

1 2 0 7

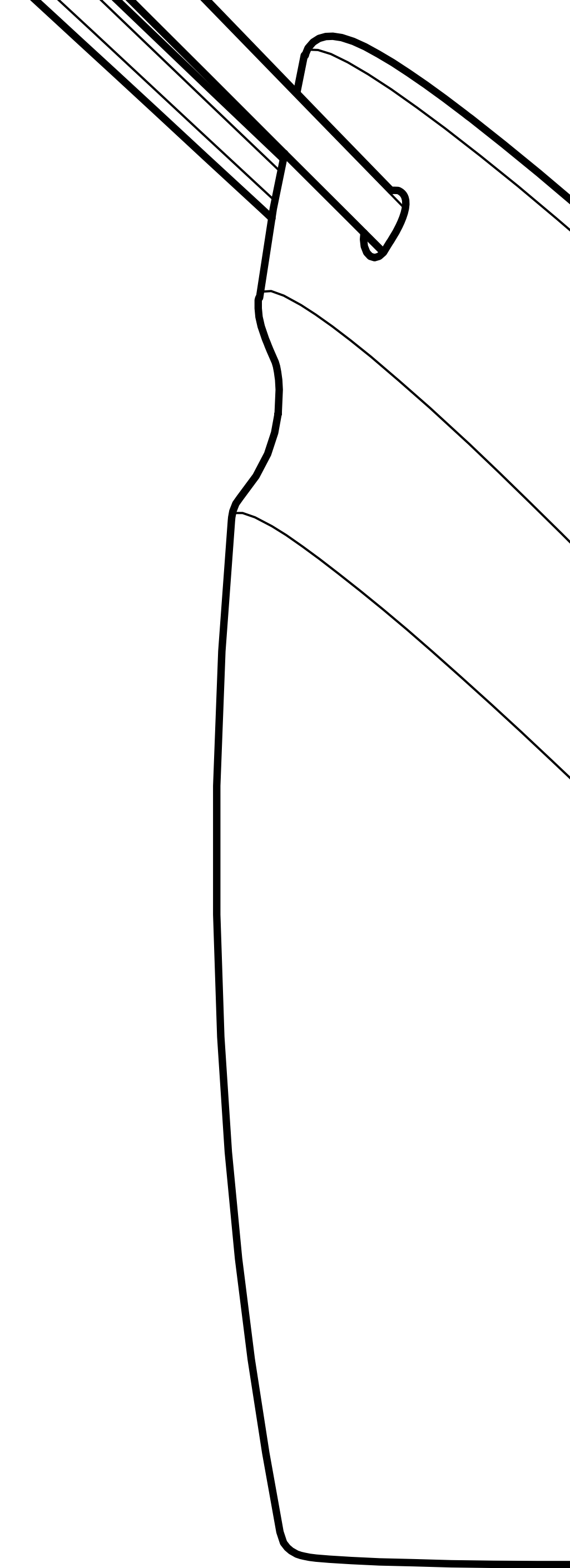

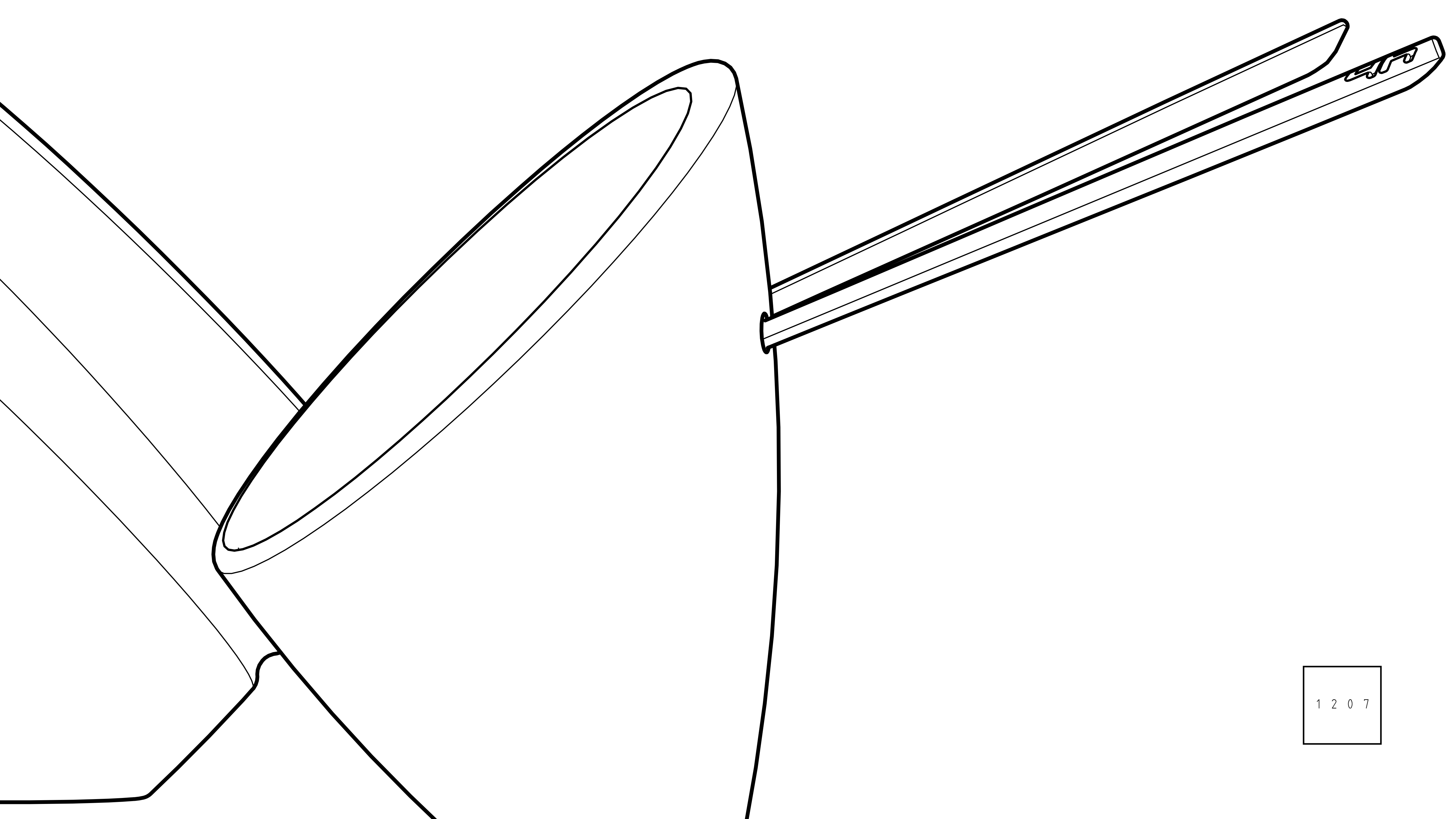

1 2 0 7

M U D
1 0 0



N A T U R A L
W H I T E



N A T U R A L
B L A C K



B L A C K
S A N D P A P E R



B L A C K

W H I T E
O C T A V I O



W H I T E
S A M U R A I . M



W H I T E
S A M U R A I . L



W H I T E
A K U



W H I T E

N G L . 8 0

L M . 9 0

A P . 9 0

N T . 0 0

B L . 1 0 0

N G . 1 0 0

N O H O & X I
F I N I S H E S

—
N O H O
&
X I

The Otomi words meaning fat and skinny give name to this Kit of oil and vinegar containers, or contain any other liquid; and even used as vases.



**N O H O
&
X I**

P a i r o f h i g h
t e m p e r a t u r e c e r a m i c
c o n t a i n e r s
(S t o n e w a r e / c o n e 5)
e n a m e l f i n i s h e s ,

e n g o b e o r m o d e l s w i t h c e r a m i c
d e c a l (b u r n e d) . T h e y h a v e c o r k
s t o p p l e s .

C a p a c i t y : O i l c o n t a i n e r . - 7 5 0 m l
a n d v i n e g a r c o n t a i n e r 6 5 0 m l .

D i m e n s i o n s : O i l c o n t a i n e r . - 1 2
x 1 2 x 2 2 c m a n d v i n e g a r
c o n t a i n e r 1 2 x 1 0 x 2 2 c m .

1 2 0 7

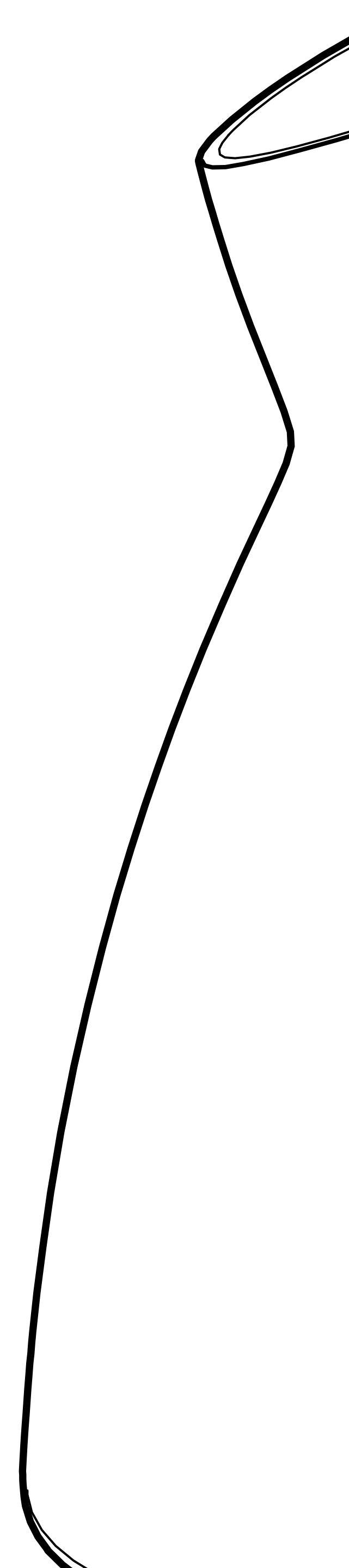

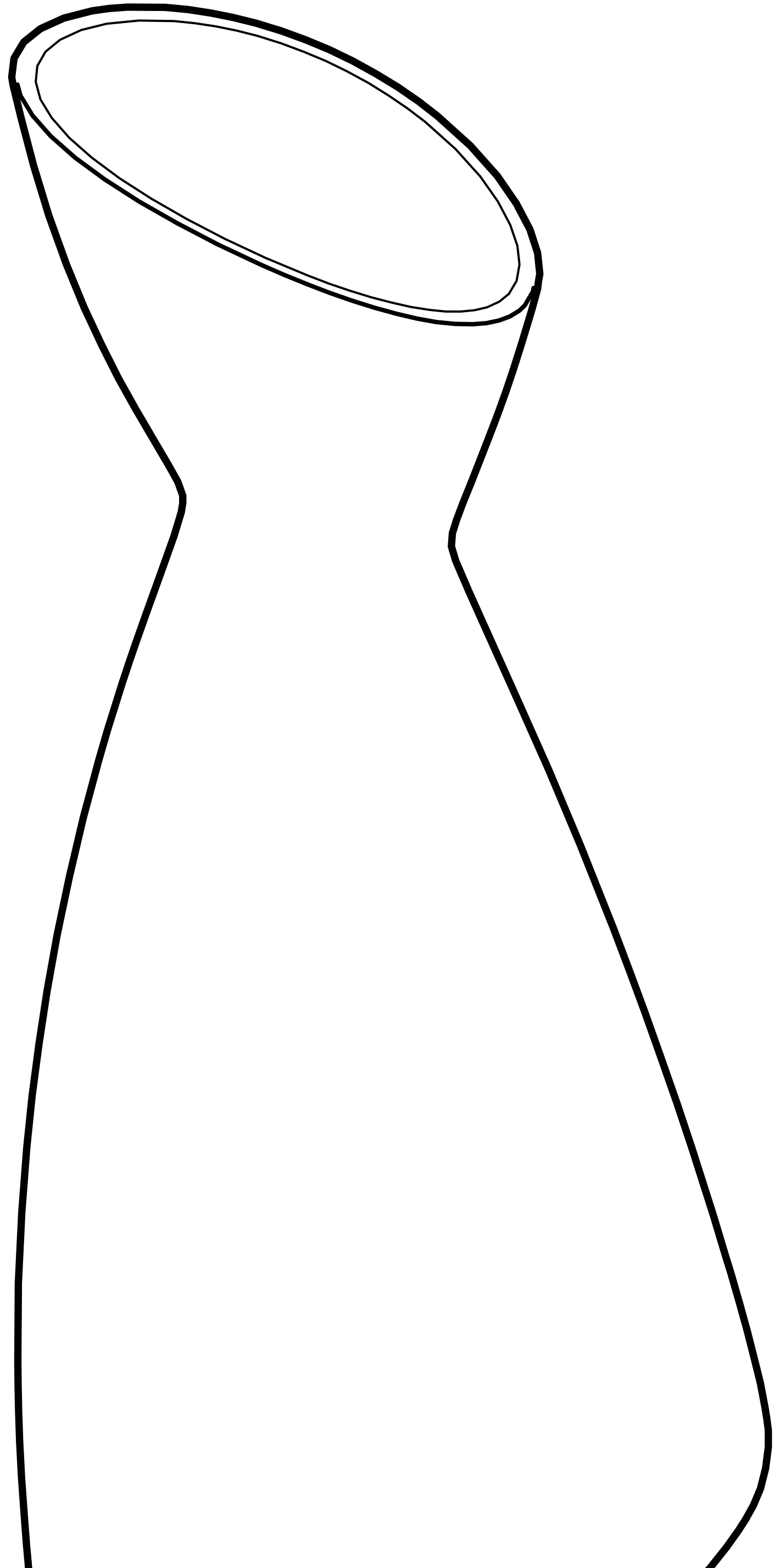
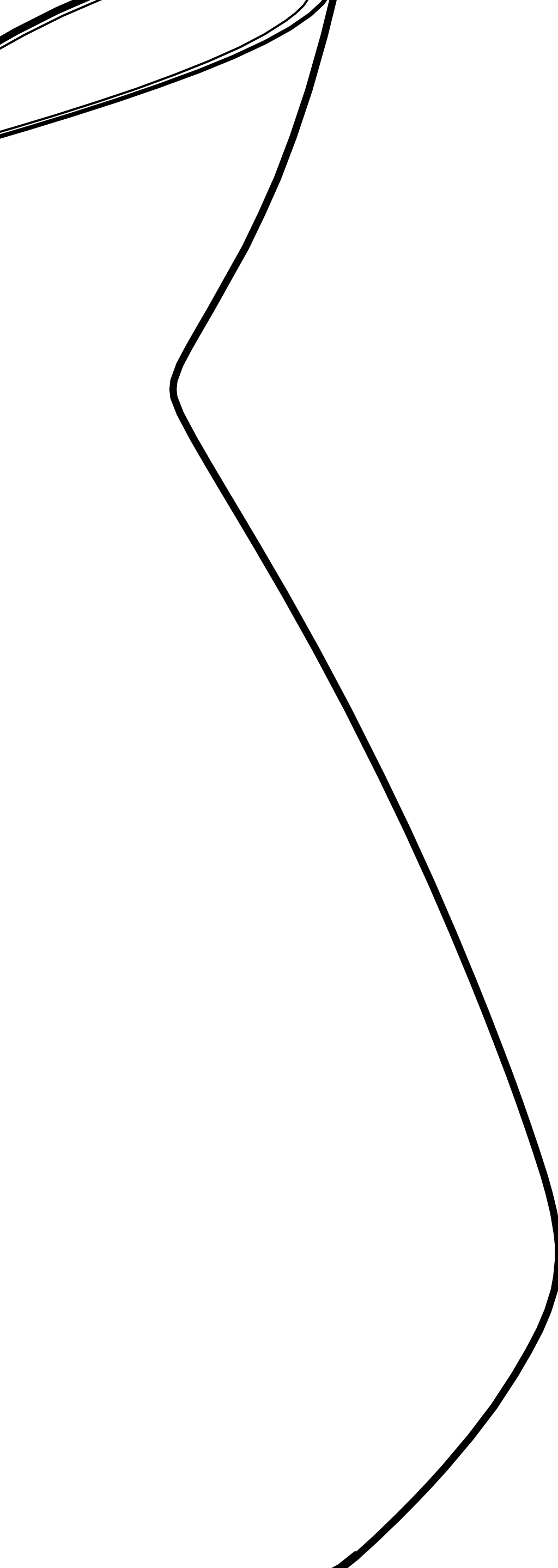

1 2 0 7



NATURAL
BLACK
WHITE



BLACK
WHITE



BLANCO
SAMURAI



BLACK.SANDPAPER
LEMON
TURQUOISE

N G L . 8 0

L M . 9 0

A P . 9 0

B R . 1 0 0

N T . 0 0

B L . 1 0 0

N G . 1 0 0

D Ö M D O
F I N I S H E S

—
D Ö M D O

Word of Otomi
origin that means
always alive. This
pot refers to its
name, as it has
its own container
so that the plant
does not lack
water at any time.



DÖMDO

High temperature ceramic flower pot (Stone-ware / cone 5) enamel finishes with ceramic decal, or engobe. Compose of 2 pieces, the body and the base (water container).

It is designed primarily for orchids, or other air roots plants or short one, as succulents.

Size: 7 inches in diameter with a total measure of 19 x 21 cm.

Container capacity: 400 ml.

1 2 0 7

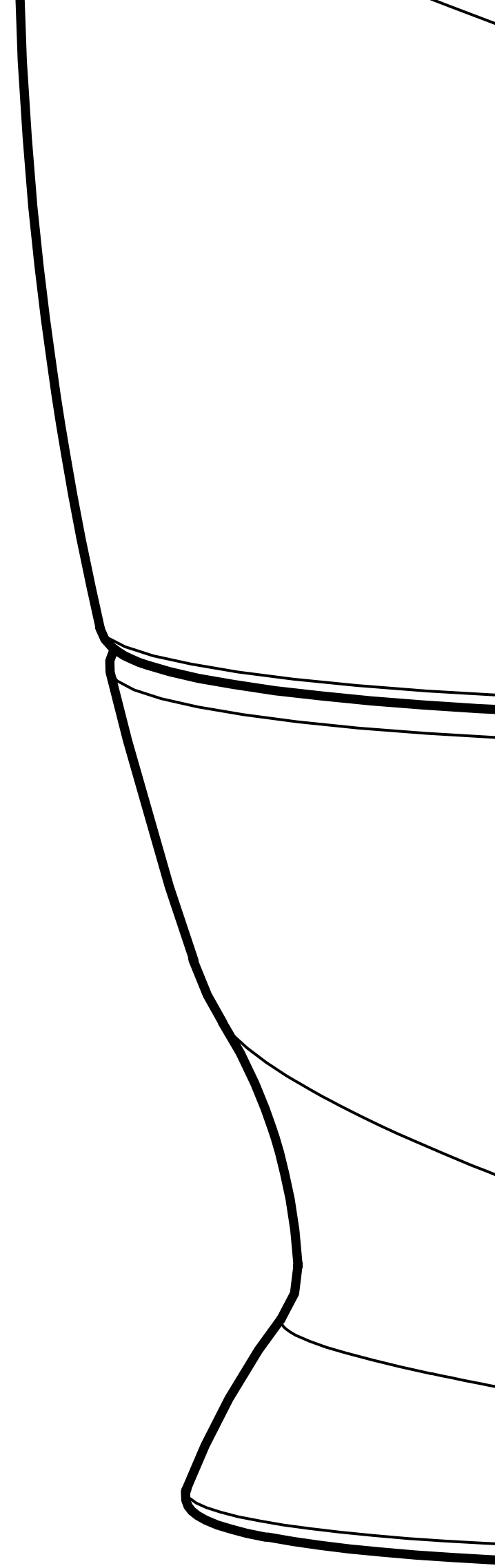



1 2 0 7

NATURAL
TURQUOISE



M U D
W H I T E



B L A C K
S A N D P A P E R
L E M O N



W H I T E



B L A C K

N G L . 8 0

L M . 9 0

B L . 1 0 0

N G . 1 0 0

K I I W
F I N I S H E S



—
K I I W

This Mayan word means a gave mezcalero and gives its name to this unique decanter because it is designed for mezcal, but can also contain any other liquid.



K I I W

High temperature
ceramic container
(Stone-ware / cone 5)
bright enamel

finishes or engobe. It has a
cork stopple. Ergonomically it
favors its unique shape for
better grip and the tilt at the
peak help to pour liquid
better.

Capacity: 600 ml.

Dimensions: 6 x 14 x 26 cm.

1 2 0 7

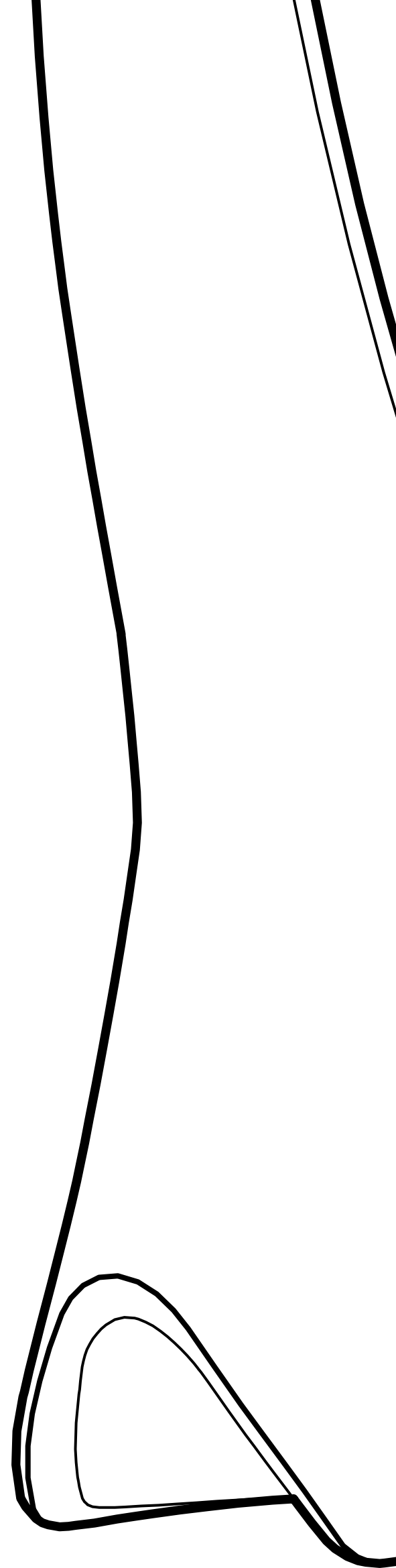



1 2 0 7

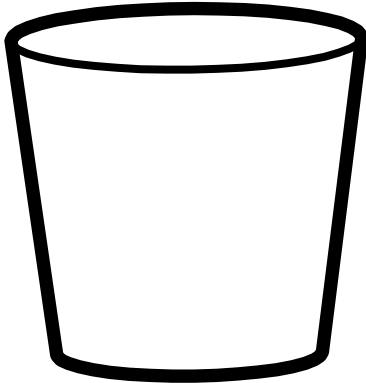

BLACK.SANPAPER
B L A C K

W H I T E



B L A C K

C T R . 8 0

N G L . 8 0

A P . 9 0

B R . 5 0

N T . 0 0

U V . 9 0

S L . 1 0 0

H A C H
F I N I S H E S

HACH

The Mayan word Hach used as superlative so, gives this pair of small bowls, which can be used to contain products as diverse as liquids, coffee, fruit, desserts, among many others.



HACH

Pair of high temperature ceramic bowls (Stone-ware / cone 5) in bright enamel finishes, matt, metallic and engobes.

With walnut Jocha and mahogany plywood bases of 5mm or 3mm, cut off and engraved on laser.

Capacity: 110 ml.

Dimensions: 6 x 7 cm.

Based Measurements: Diameter 7.5 cm.

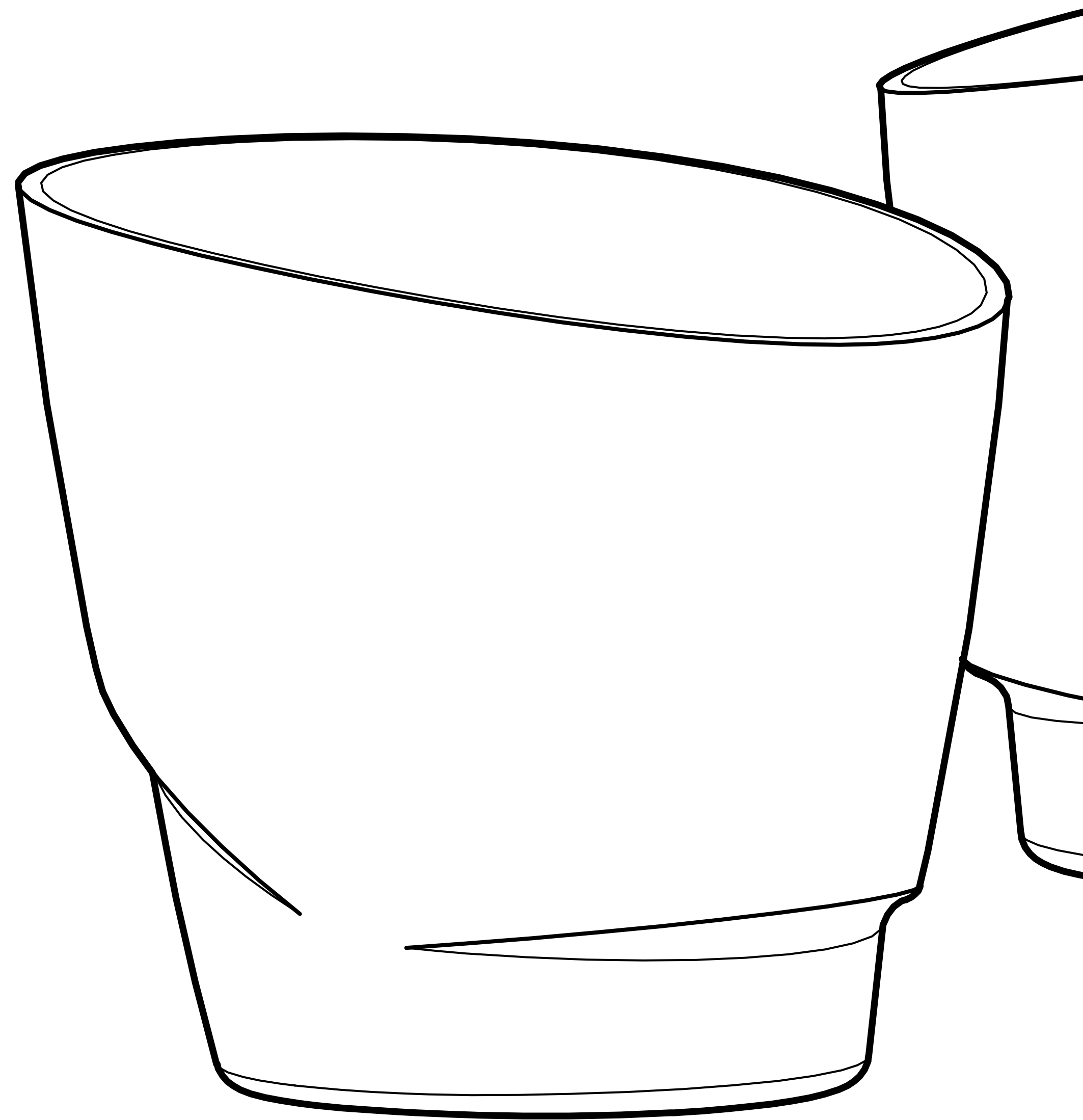

1 2 0 7



1 2 0 7

N A T U R A L
T U R Q U O I S E



B O W L

G L A S S



B L A C K . S A N P A P E R
S A L M O N



C O F F E E
B R O N Z E



C O N C R E T E
G R A Y



M A T T E
B L A C K
W H I T E

B L A C K . S A N D P A P E R
G R A P E



YALHA
FINISHES

N G L . 8 0

L M . 9 0

C T R . 8 0

B R . 1 0 0

B L . 1 0 0

N G . 1 0 0



—
Y A L H A

F l o w e r p o t
symbolizing the
prehispanic
incense bowl. In
Zapotec, the word
Yalha means copal.
Yalha is two in one
object, being that
the pot and dish
are one piece.



YALHA

High temperature ceramic flower pot (Stone-ware / cone 5) bright enamel finishes and combination with engobe. The base is produced in several processes, the first one, Birch multilayer plywood legs in CNC cutting of 18 mm thickness, then sealed with acrylic matte varnish. The metal structures produced in laser cutting, support ring in 14 gauge (1.9mm) black metal sheet and the lower structures in 18-gauge (1.2mm) black metal sheet, then with electro-paint bright white as base and a surface layer of fluorescent acrylic enamel (to generate a visual effect of the structure wear); and finally stainless steel metric screws of 3mm; for its assembly. Dimensions: diameter of 7 inches. Total: 19 x 20 cm. Models with multilayer plywood base in 2 sizes: 92 and 46 cm high.

1 2 0 7

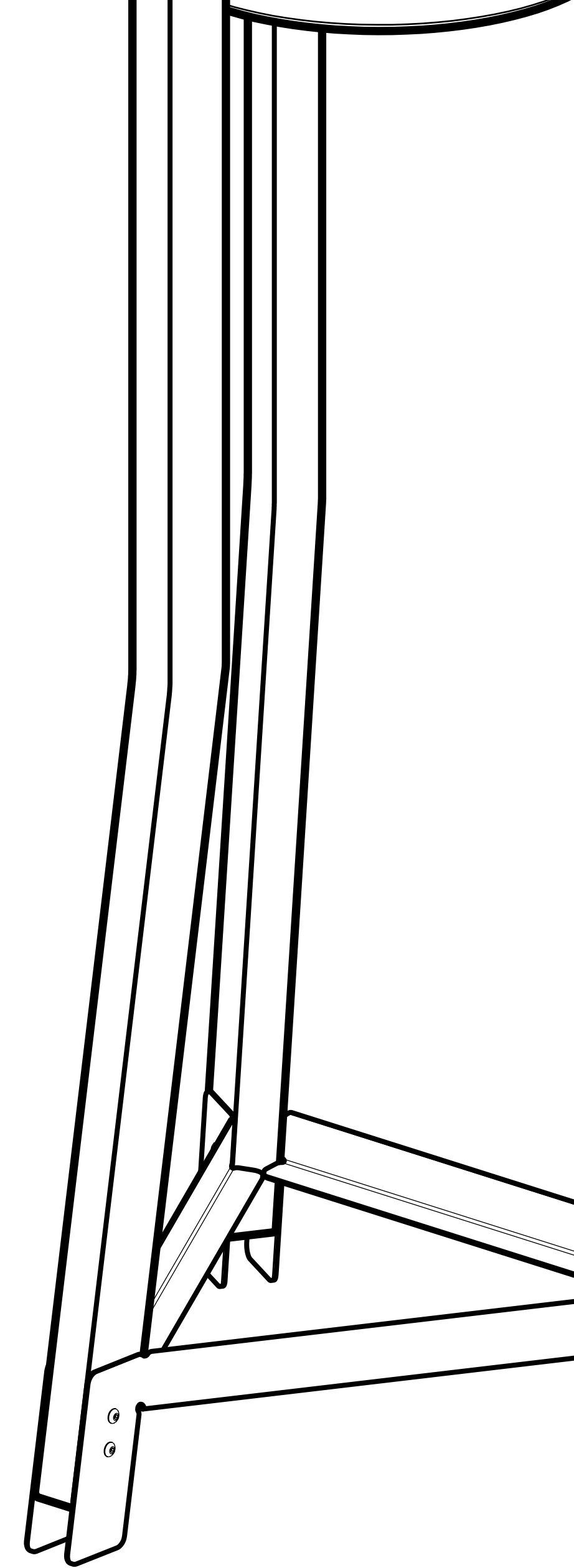

1 2 0 7

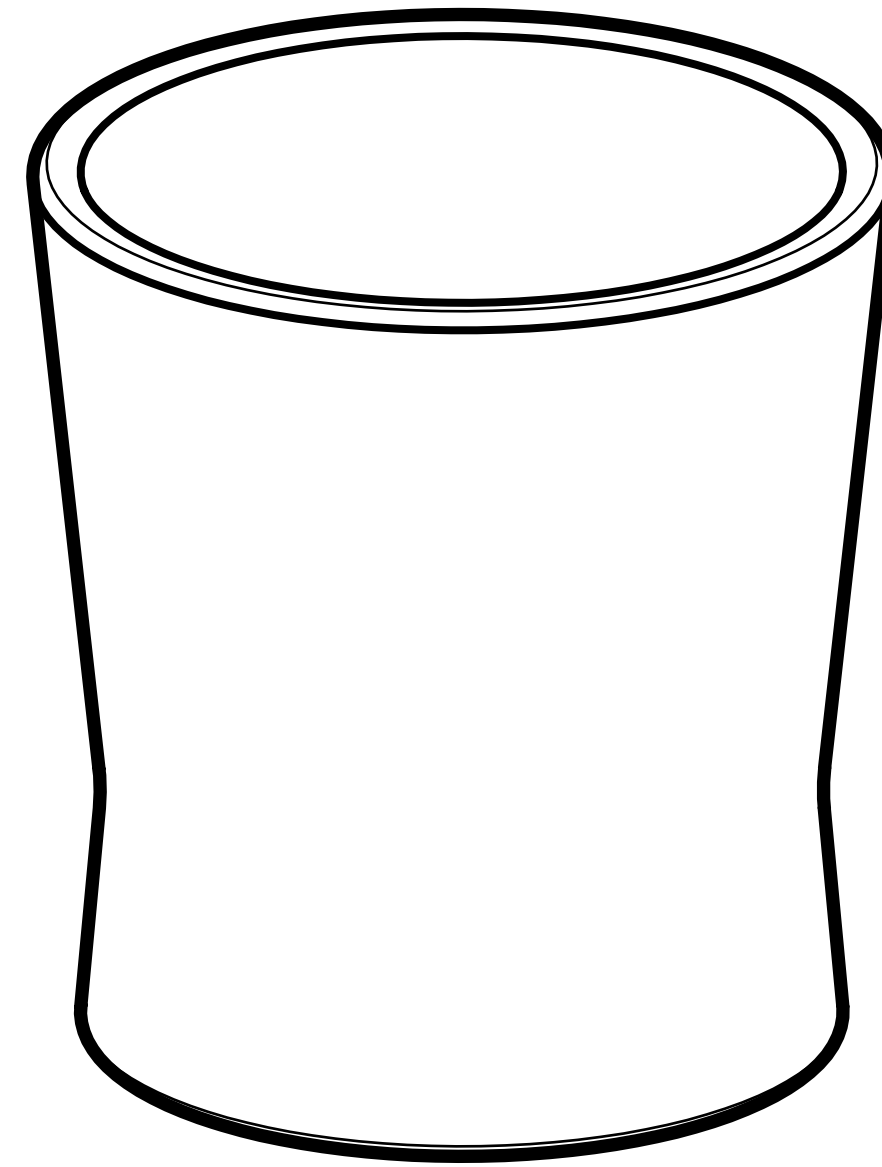
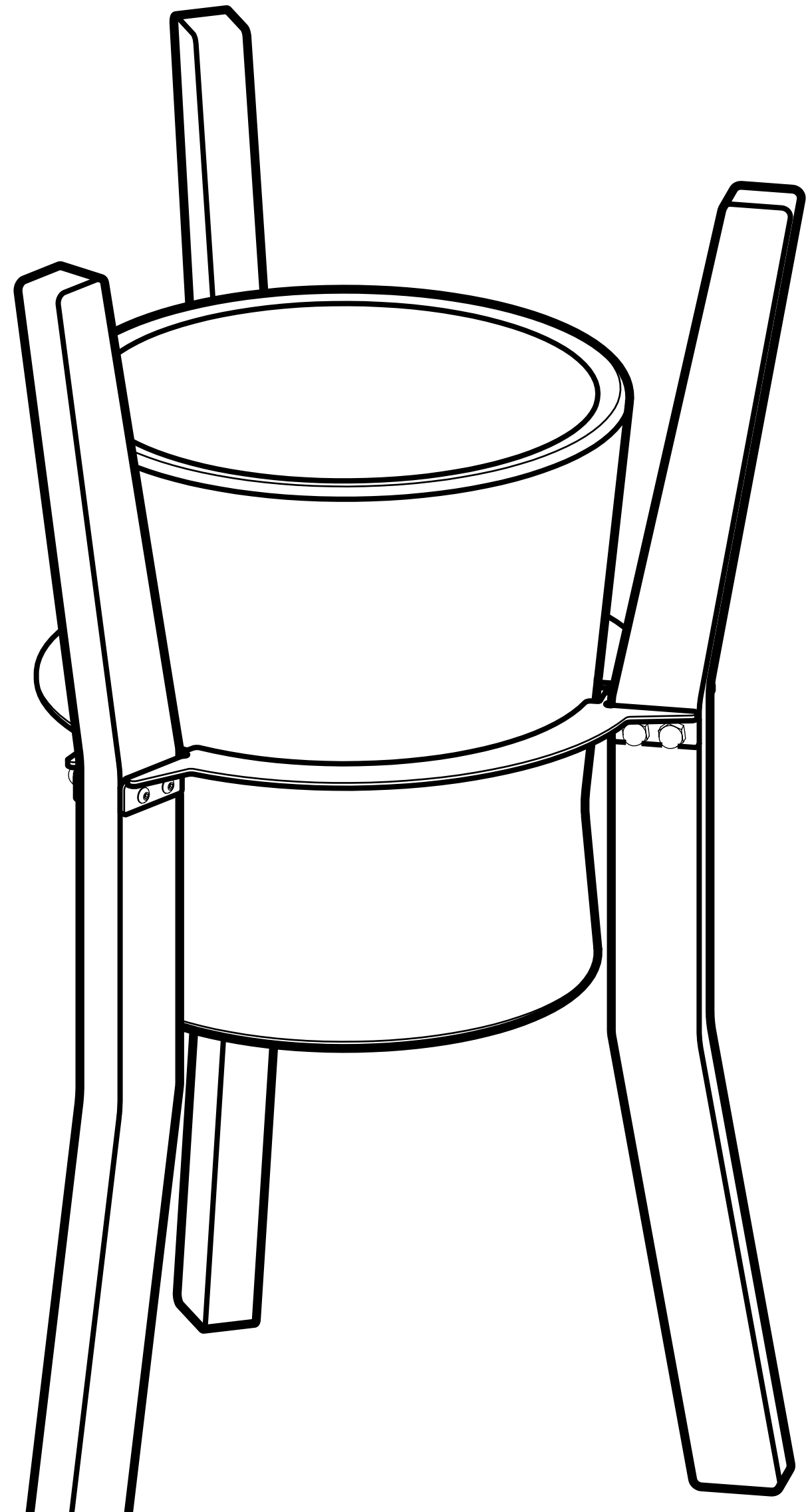
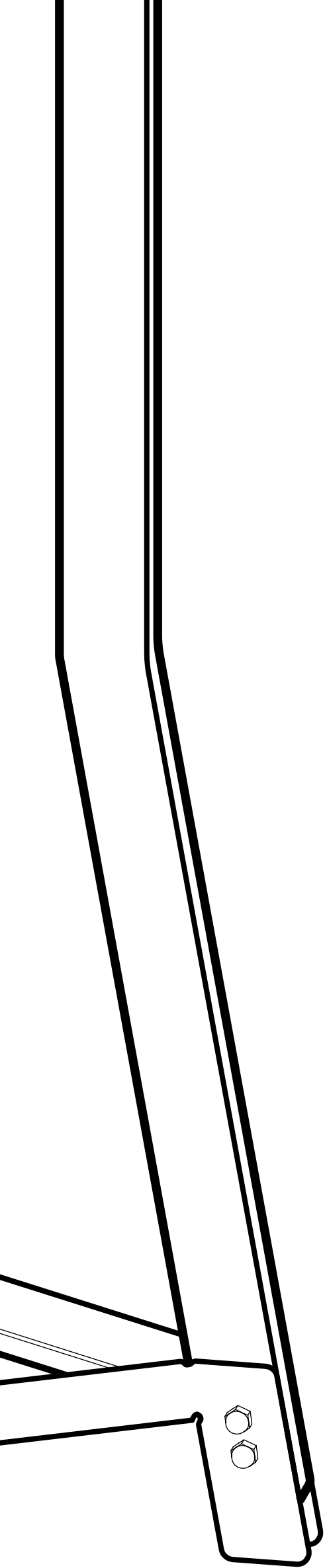



B L A C K
B I R C H



W H I T E



B L A C K



W H I T E
B I R C H

CH'OOY
FINISHES

N G L . 8 0

B R . 1 0 0

B L . 1 0 0

N G . 1 0 0

—
CH'OOY

Set of 3 pots.
Also of Mayan
origin, the word
Ch'oooy meaning
cube, gives its
name to the
products of this
geometric
figure.



CH'OOY

Individual pot (pot body and base plate) or 3-piece set; high temperature ceramic

(Stone-ware / cone 5) bright enamel finish or matte combination with engobe.

The structure is produced of 3/16" steel rod, bent and welded. Electro-paint base and fluorescent enamel or color as an extra coating (to generate a visual effect of the structure wear); with rubber ferrules.

Size: 20 x 15 cm complete with plate, standard capacity 9-inch pot.

Metal base Dimensions: 20 x 60 x 21cm.

1 2 0 7

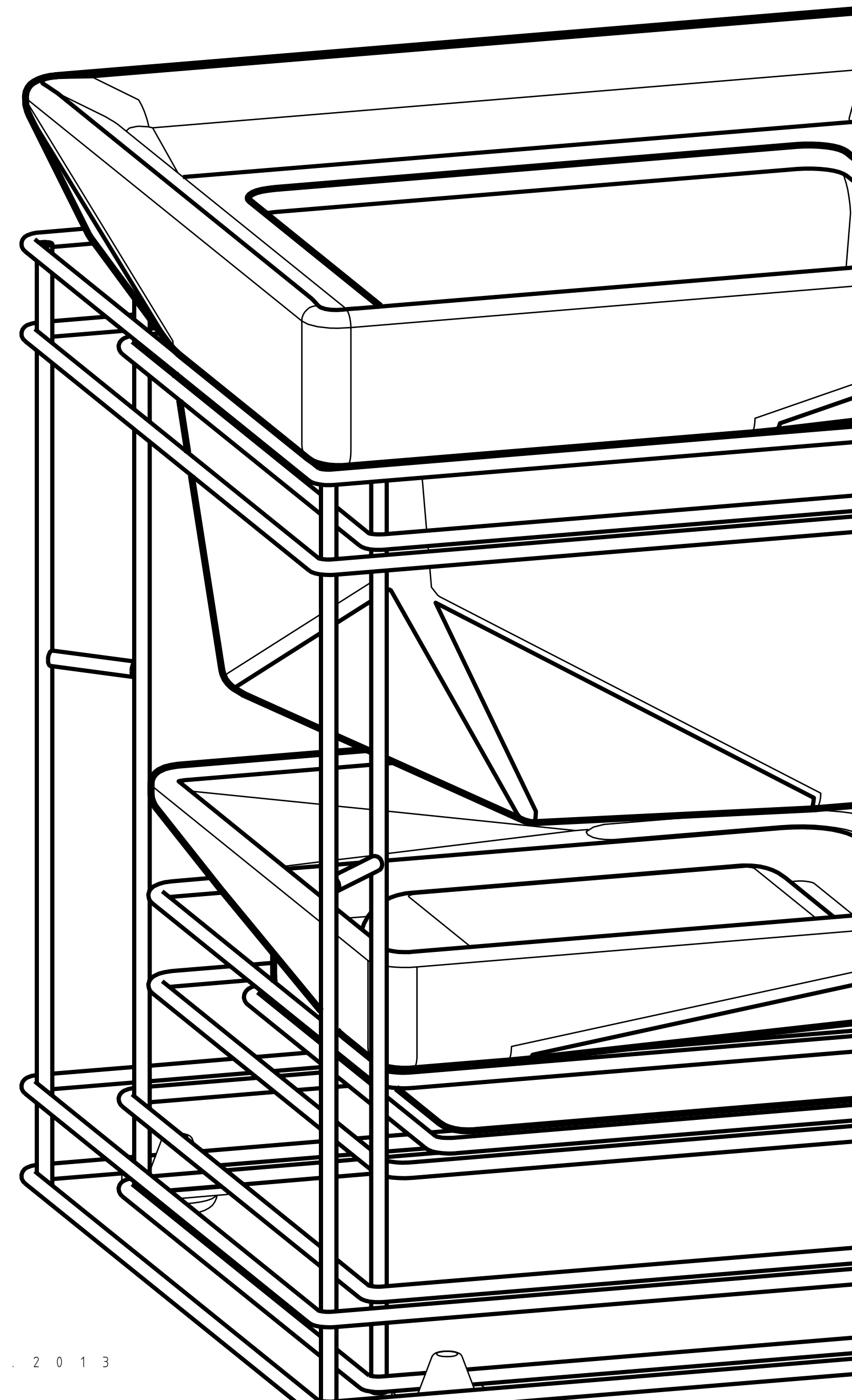

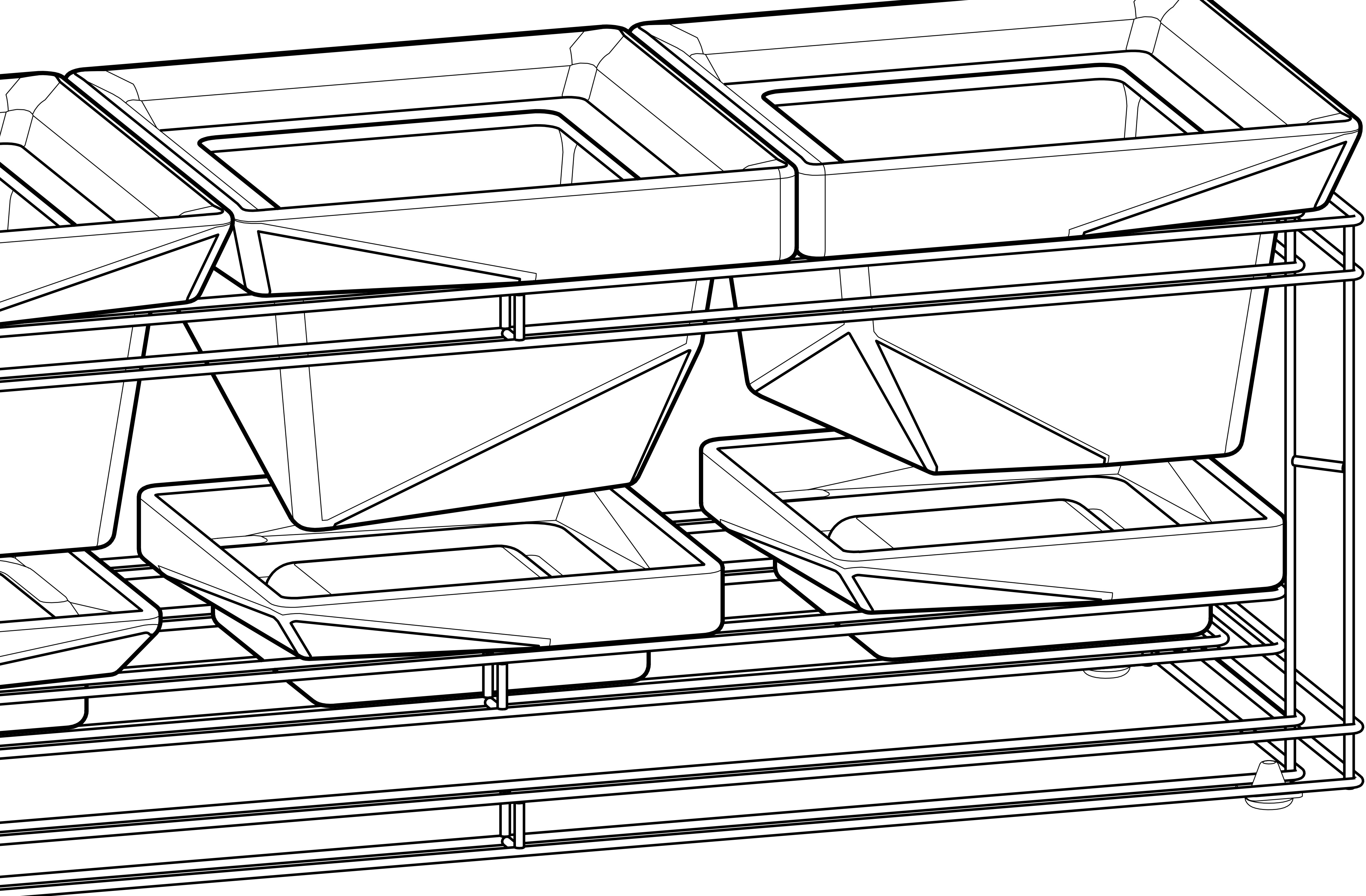

1 2 0 7

M U D
1 0 0



W H I T E

B L A C K
S A N D P A P E R



B L A C K



N G L . 8 0

L M . 9 0

N T . 0 0

A P . 9 0

B L . 1 0 0

N G . 1 0 0



—
P I S A

V a s e w h o s e
n a m e r e f e r s
t o t h e f a m o u s
I t a l i a n t o w e r
o f P i s a , b y
i t s
i n c l i n a t i o n .



PISA

High temperature ceramic vase (Stoneware / cone 5) enamel finishes and combined with engobe or natural material. There are models with ceramic decal (burned).

Dimensions: 10 x 12 x 25 cm.

1 2 0 7

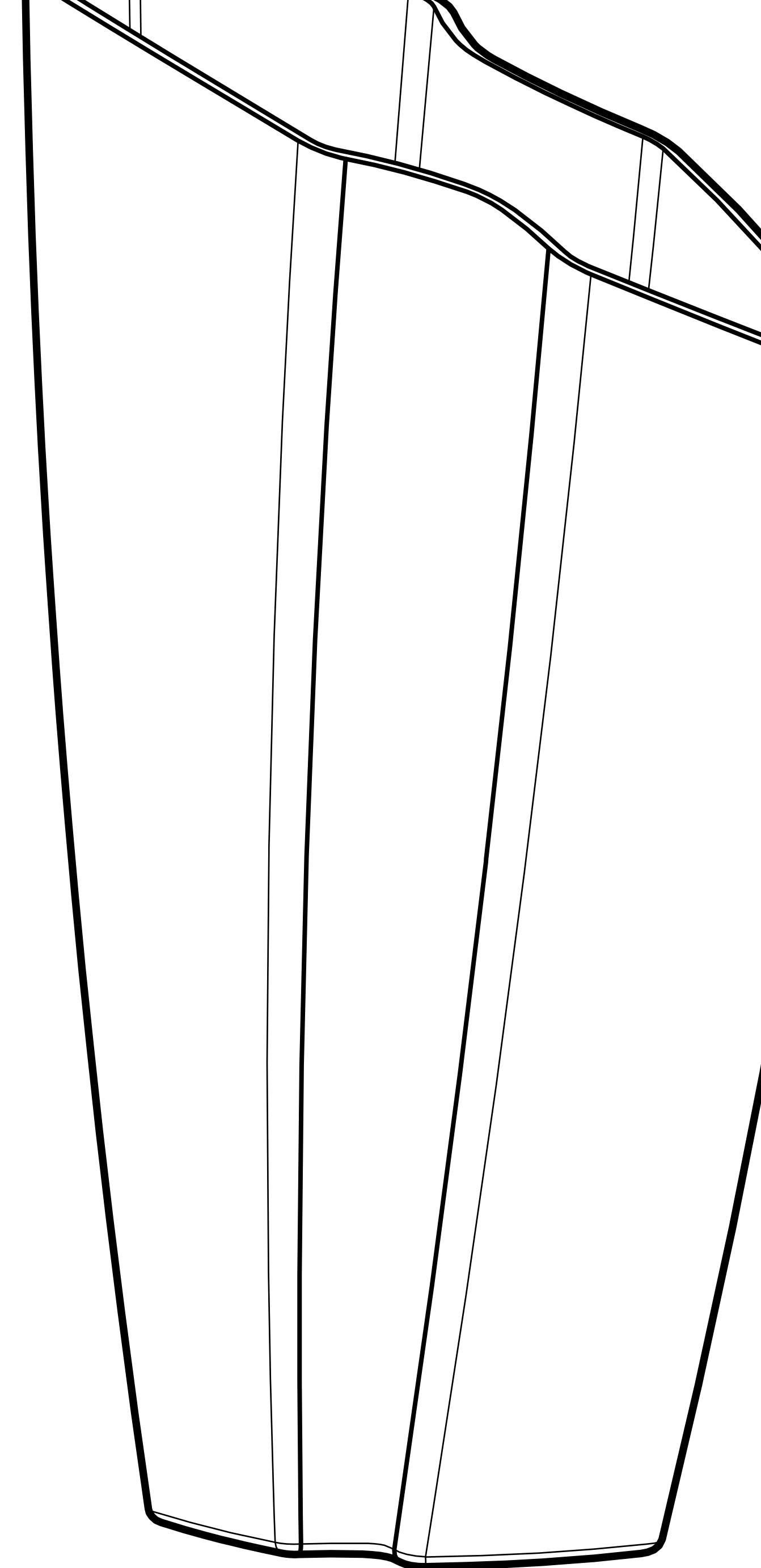

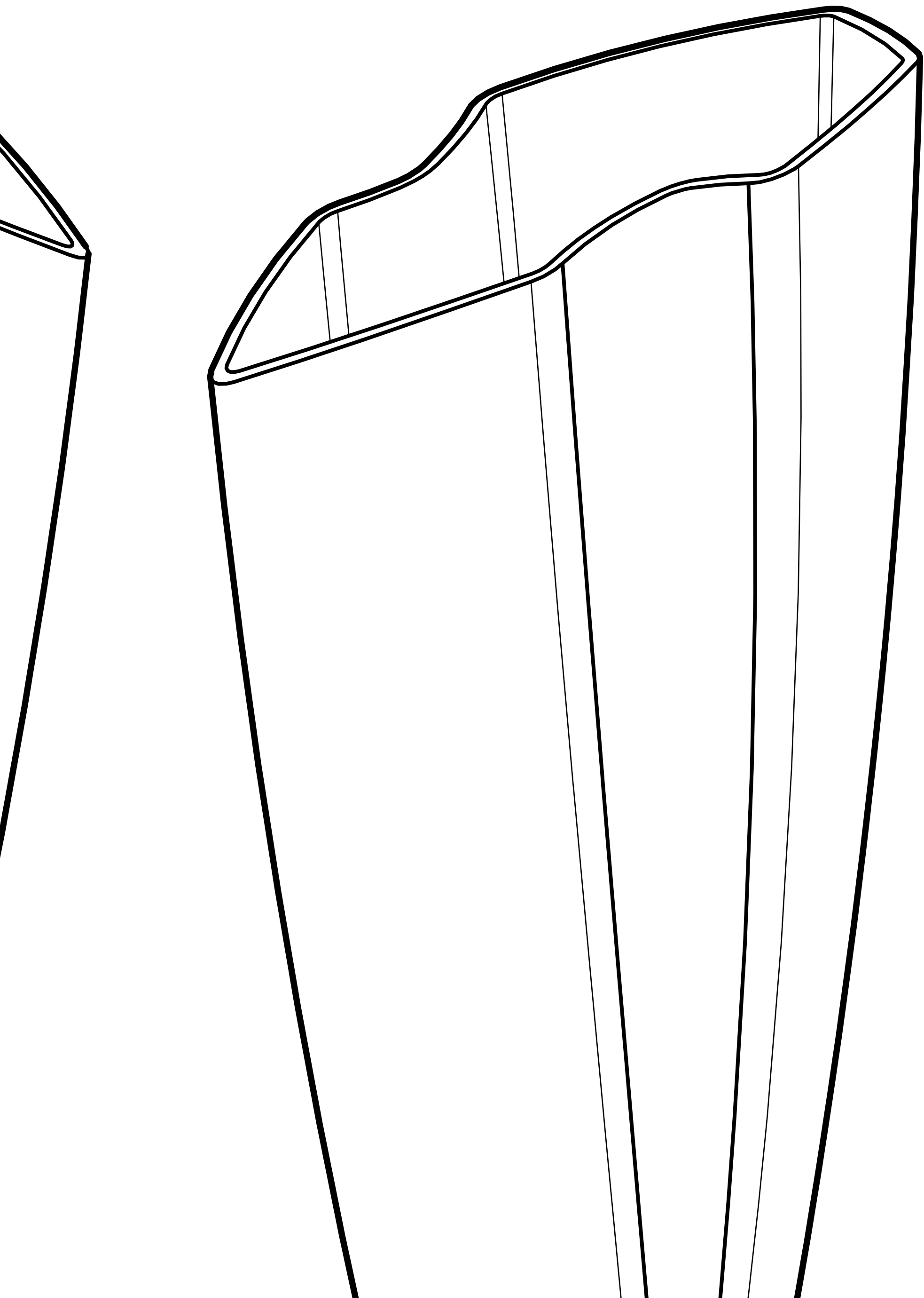

1 2 0 7

BLACK
NATURAL



WHITE
DECAL



WHITE
NATURAL

BLACK.SANDPAPER
LEMON



B L . 1 0 0

L É E T S '
 F I N I S H E S

N G . 1 0 0



—
L É E T S '

Word that means
light of fire.
Candleholder
with candles of
different
aromas. They can
also be used as
mini pots.



LÉETS'

Set of 3 high temperature ceramic candle holders (Stone-ware / cone 5)

in bright enamel finishes. There are models with ceramic decal (burned).

With handmade candles of various scents.

There are 2 base models; the first is mahogany, walnut and Jocha plywood base of 5mm, laser cut; and finally are coated with matte sealer.

The other model is transparent acrylic base of 3mm, laser cut, and then bent to heat.

Total Size: 13 x 12 x 25 cm.

1 2 0 7

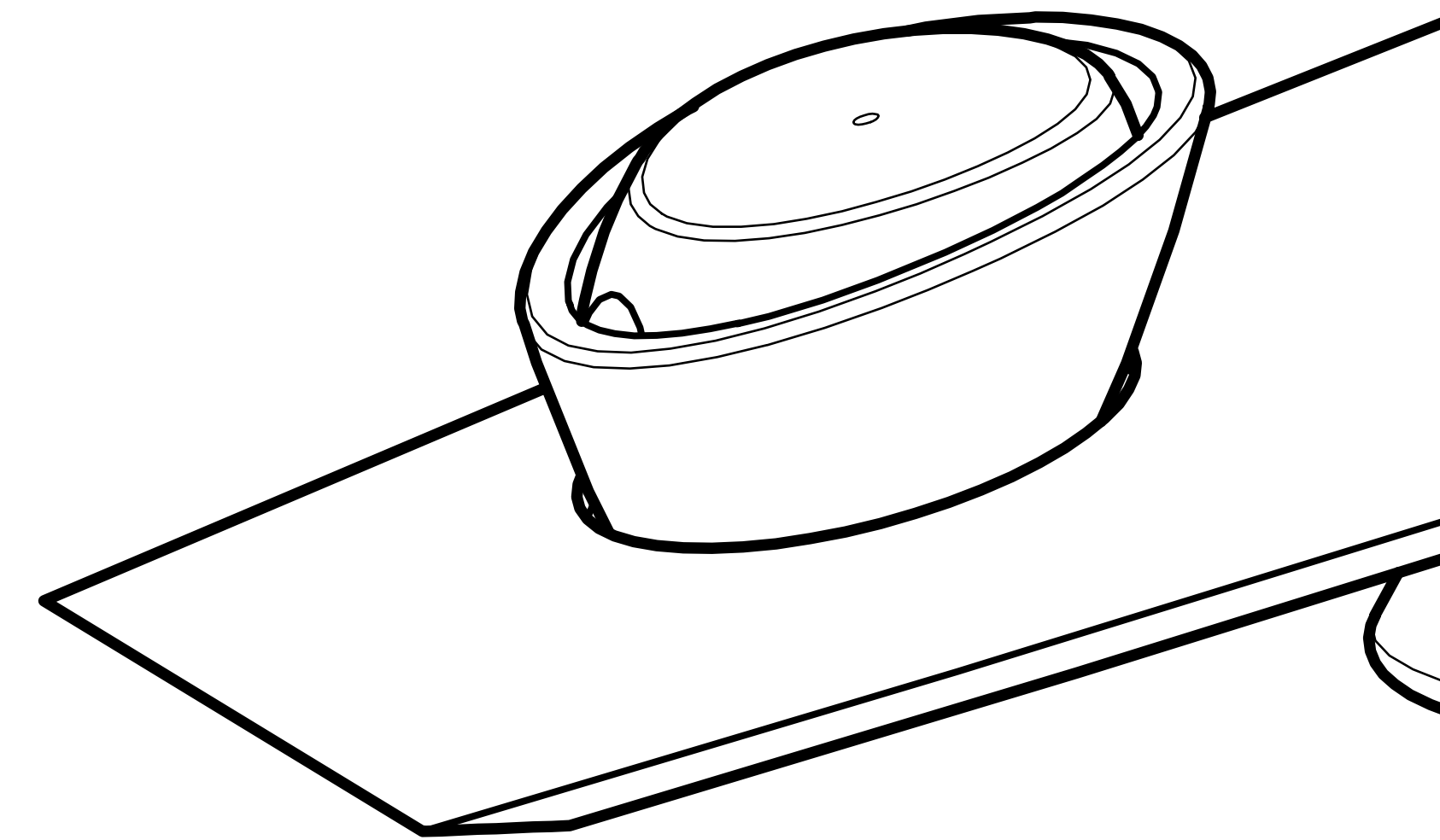

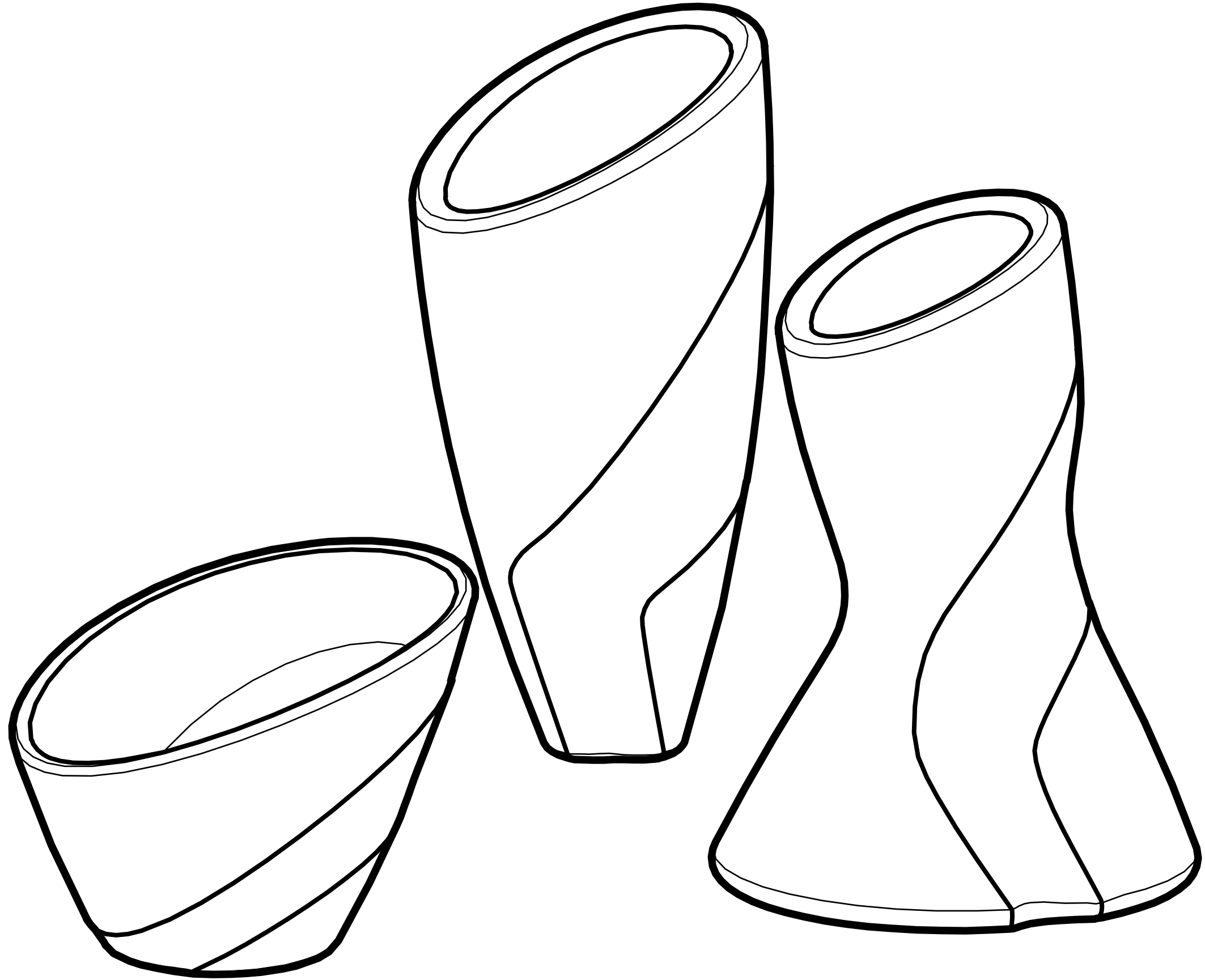
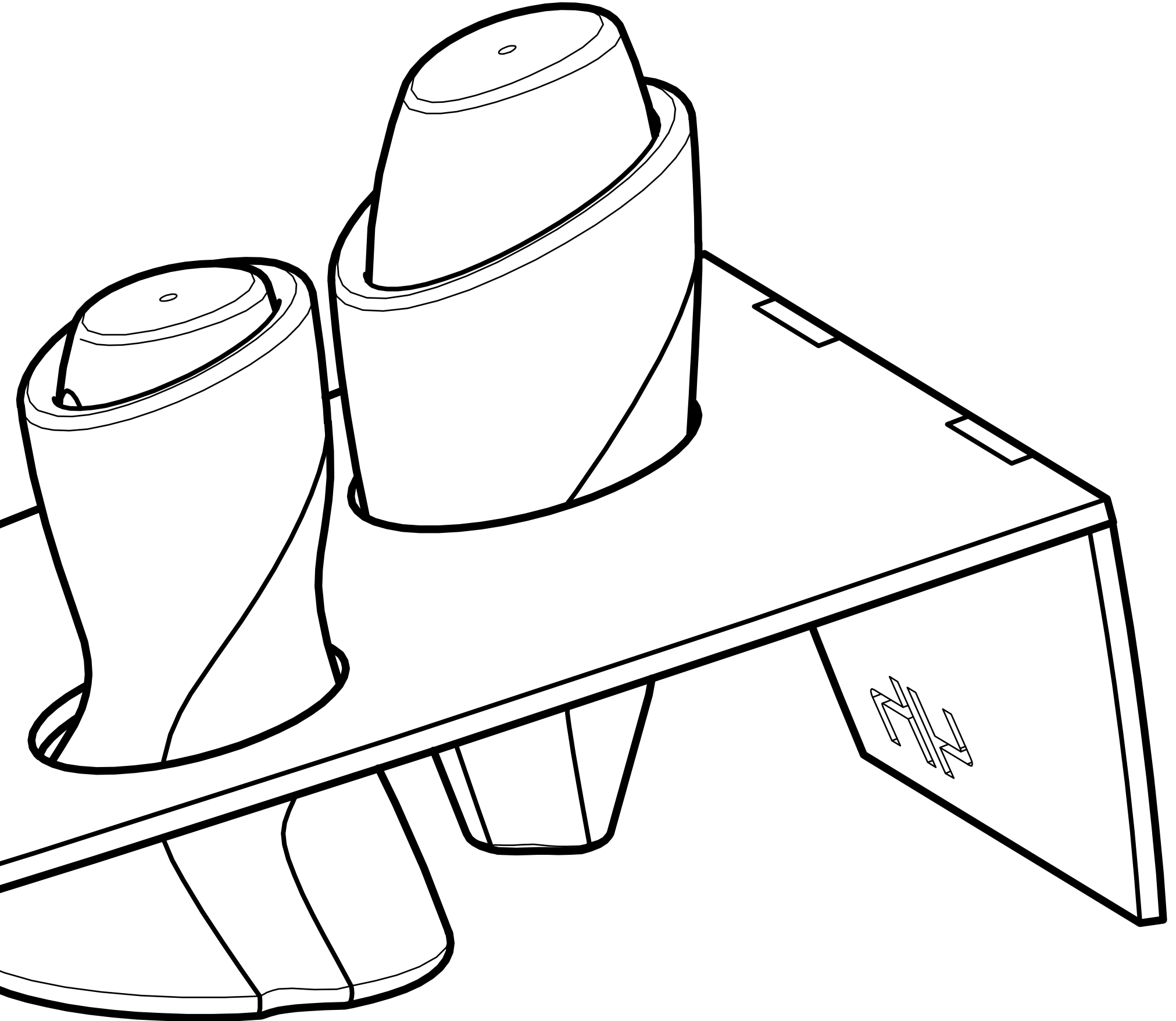

W H I T E
M A H O G A N Y



B L A C K
J O C H A



W H I T E
A C R Y L I C



W H I T E
W A L N U T



FINISHES

If you want to make special requests, we have a wide range of finishes for your choice in our models.



Natural



Mud 100



Coffee

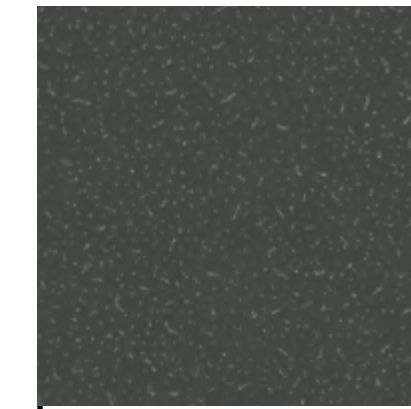

Concrete

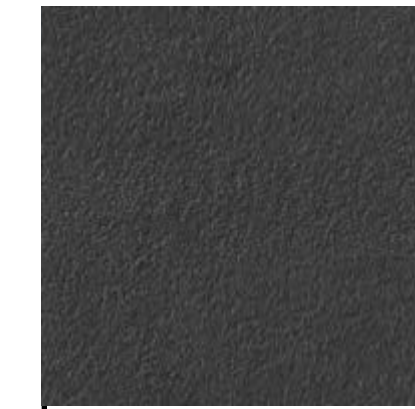

Black Sandpaper



Blue Sandpaper



Transparent



Yellow



Orange



Tomato



Pink



Blue



Gray



White



Black



Lemon



Grape



Turquoise

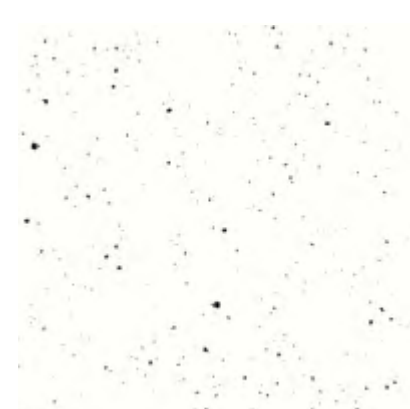

Mottled

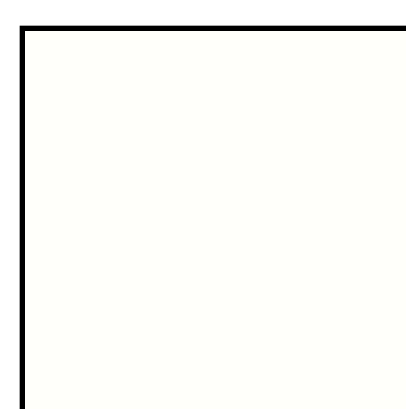

Matte White



Matte Black



Salmon



Bronze



Gold

WE HAVE A WIDE RANGE OF FINISHES AND COMBINATIONS, FOR OUR PRODUCTS OR ANY DESIGN ...

A50 - 7Cu5
1030° / 1207°
Mex. - Mor.

P R O P E R T I E S

STONEWARE

F R E E Z I N G



M I C R O W A V E

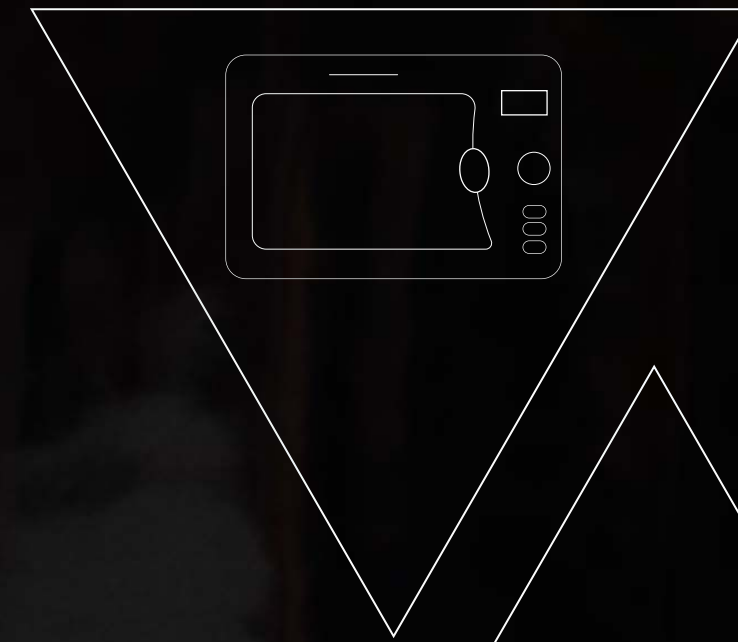

F I R E . M A X . 5 0 °



A C I D S





Y O H O
C E R A M I C

f / y o h o c e r a m i c

@ y o h o c e r a m i c

/ y o h o c e r a m i c

Bē y o h o - c e r a m i c

@ y o h o c e r a m i c

w w w . y o h o - c e r a m i c . c o m

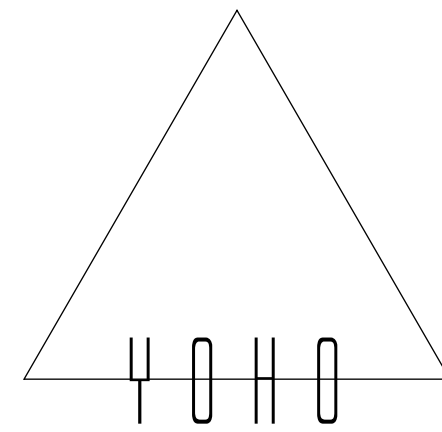

Y O H O
D E S I G N - M É X I C O

D I . M a n u e l E . M .

0 4 4 - 5 5 - 2 5 0 1 1 3 8 5
5 6 9 5 6 3 3 6 _ 5 5 7 1 5 0 4 1

d i @ y o h o - c e r a m i c . c o m
h e l l o @ y o h o - c e r a m i c . c o m

M i g u e l . O l i v a r e s . 3 3
P r e s i d e n t e s . E j i d a l e s
C o y o a c á n . M e x i c o

| C e r a m i c | I n d u s t r i a l
I n t e r i o r | G r a p h i c